

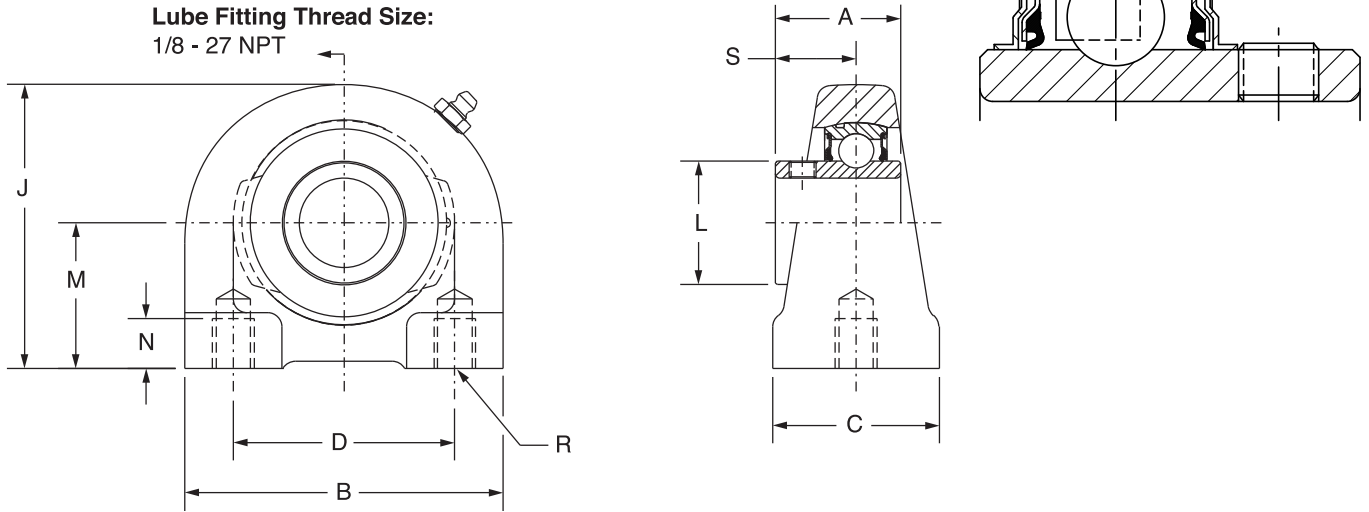

SELECTION/DIMENSIONS

Setscrew Ball Bearings SC NORMAL DUTY TAPPED BASE PILLOW BLOCKS



Series	Shaft Size	Part No.	Description
204	1/2	124460	TB-SC-008
	5/8	124461	TB-SC-010
	3/4	124462	TB-SC-012
	20mm	130354	<i>TB-SC-20M</i>
205	7/8	124463	TB-SC-014
	15/16	124464	TB-SC-015
	1	124465	TB-SC-100
	25mm	130355	<i>TB-SC-25M</i>
206	1-1/16	124466	TB-SC-101
	1-1/8	124467	TB-SC-102
	1-3/16	124468	TB-SC-103
	1-1/4	124469	TB-SC-104S
	30mm	130356	<i>TB-SC-30M</i>
207	1-1/4	124470	TB-SC-104
	1-5/16	124471	TB-SC-105
	1-3/8	124472	TB-SC-106
	1-7/16	124473	TB-SC-107
	35mm	130357	<i>TB-SC-35M</i>
208	1-1/2	124479	TB-SC-108
	1-5/8	128998	TB-SC-110
	40mm	130358	<i>TB-SC-40M</i>
209	1-5/8	049859	TB-SC-110L
	1-11/16	054548	TB-SC-111
	1-3/4	054781	TB-SC-112
	45mm	130359	<i>TB-SC-45M</i>
210	1-15/16	124478	TB-SC-115
	2	052472	TB-SC-200
	50mm	130360	<i>TB-SC-50M</i>
211	2	124480	TB-SC-200L
	2-3/16	050386	TB-SC-203
	2-1/4	054436	TB-SC-204
	55mm	130361	<i>TB-SC-55M</i>

SELECTION/DIMENSIONS



Setscrew Ball Bearings SC NORMAL DUTY TAPPED BASE PILLOW BLOCKS

Bearing Reference Guide

ULTRA KLEEN

E-Z KLEEN

Extreme Duty

Setscrew Ball Bearing

GRIP TIGHT

D-LOK Ball Bearing

Series	Shaft Size	Weight lbs. kgs.	A	B	C	D	J	L	M	N	R	S
204	1/2	1.56	1.23	2.88	1.50	2.00	2.56	1.12	1.31	0.50	3/8-16	0.73
	5/8	1.53										
	3/4	1.50										
	20mm	0.06	31.2	73.2	38.1	50.8	65.0	28.4	33.4	12.7	M8x1.25	18.5
205	7/8	1.93	1.34	3.00	1.50	2.00	2.81	1.32	1.44	0.50	3/8-16	0.78
	15/16	1.90										
	1	1.87										
	25mm	0.07	34.0	76.2	38.1	50.8	71.4	33.5	36.5	12.7	M10x1.5	19.8
206	1-1/16	2.66	1.52	4.00	1.50	3.00	3.38	1.57	1.69	0.63	7/16-14	0.94
	1-1/8	2.62										
	1-3/16	2.59										
	30mm	0.10	38.6	101.6	38.1	76.2	85.9	39.9	42.9	16.0	M10x1.5	23.9
207	1-1/4	3.41	1.71	4.25	1.88	3.25	3.75	1.84	1.88	0.75	1/2-13	1.04
	1-5/16	3.36										
	1-3/8	3.34										
	35mm	0.13	43.4	108.0	47.8	82.6	95.3	46.7	47.6	19.1	M10x1.5	26.4
208	1-1/2	4.10	1.94	4.63	1.88	3.50	3.94	2.05	1.94	0.75	1/2-13	1.19
	1-5/8	4.00										
	40mm	0.16	49.3	117.6	47.8	88.9	100.1	52.1	49.2	19.1	M12x1.75	30.2
209	1-5/8	5.20	1.94	5.00	2.00	3.75	4.25	2.22	2.13	0.75	1/2-13	1.19
	1-11/16	5.00										
	45mm	0.20	49.3	127.0	50.8	95.3	108.0	56.4	54.0	19.1	M12x1.75	30.2
210	1-15/16	5.40	1.94	5.50	2.00	4.00	4.63	2.43	2.25	0.88	5/8-11	1.19
	2	5.20										
	50mm	0.21	49.3	139.7	50.8	101.6	117.6	61.7	57.2	22.4	M16x2	30.2
211	2	6.70	2.22	5.50	2.00	4.00	4.63	2.71	2.25	0.88	5/8-11	1.35
	2-3/16	6.50										
	2-1/4	6.30										
	55mm	0.25	56.4	139.7	50.8	101.6	117.6	68.8	57.2	22.4	M16x2	34.3

FEATURES/BENEFITS PAGE B4-3	HOW TO ORDER/NOMENCLATURE PAGE B4-5	SELECTION PAGE B4-6	ACCESSORIES PAGE B4-98
--------------------------------	--	------------------------	---------------------------