

SELECTION/DIMENSIONS

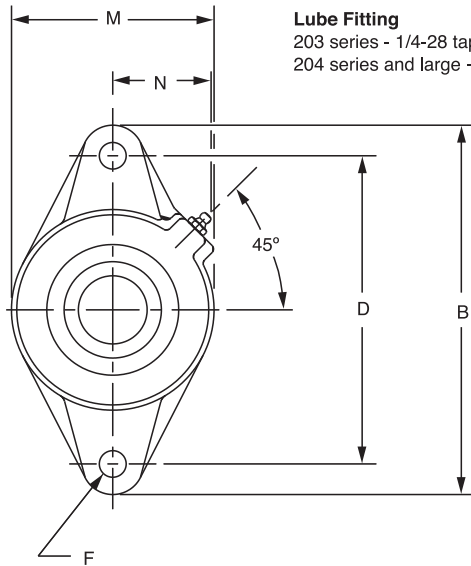

Setscrew Ball Bearings SCM MEDIUM DUTY 2-BOLT FLANGE BEARINGS



Lube Fitting
203 series - 1/4-28 tapered thread
204 series and large - 1/8-27 NPT

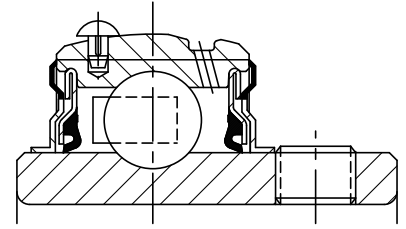
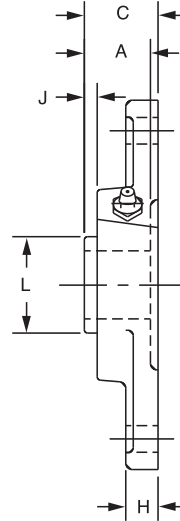

Series	Shaft Size	Standard		Sealed for Life	
		Part No.	Description	Part No.	Description
206	1	126284	F2B-SCM-100	@	F2B-SCM-100-NL
	25mm	125954	F2B-SCM-25M	@	F2B-SCM-25M-NL
207	1-3/16	126285	F2B-SCM-103	@	F2B-SCM-103-NL
	1-1/4	124276	F2B-SC-104	126518	F2B-SC-104-NL
	30mm	125955	F2B-SCM-30M	@	F2B-SCM-30M-NL
208	1-7/16	126287	F2B-SCM-107	@	F2B-SCM-107-NL
	35mm	125956	F2B-SCM-35M	@	F2B-SCM-35M-NL
209	1-1/2	126288	F2B-SCM-108	126536	F2B-SCM-108-NL
	1-5/8	125171	F2B-SC-110L	@	F2B-SC-110L-NL
	40mm	125957	F2B-SCM-40M	067674	F2B-SCM-40M-NL
210	1-11/16	126289	F2B-SCM-111	@	F2B-SCM-111-NL
	1-3/4	126290	F2B-SCM-112	@	F2B-SCM-112-NL
	45mm	125958	F2B-SCM-45M	@	F2B-SCM-45M-NL
211	1-15/16	126292	F2B-SCM-115	@	F2B-SCM-115-NL
	2	126293	F2B-SCM-200	065595	F2B-SCM-200-NL
212	50mm	125960	F2B-SCM-50M	@	F2B-SCM-50M-NL
	2-3/16	062746	F2B-SCM-203	@	F2B-SCM-203-NL
	2-1/4	073492	F2B-SCM-204	@	F2B-SCM-204-NL
	55mm	@	F2B-SCM-55M	@	F2B-SCM-55M-NL

@ Assembled to order

FEATURES/BENEFITS PAGE B4-3	HOW TO ORDER/NOMENCLATURE PAGE B4-5	SELECTION PAGE B4-6	ACCESSORIES PAGE B4-98
--------------------------------	--	------------------------	---------------------------

SELECTION/DIMENSIONS



Setscrew Ball Bearings SCM MEDIUM DUTY 2-BOLT FLANGE BEARINGS

Bearing Reference Guide

ULTRA KLEEN

E-Z KLEEN

Extreme Duty

Setscrew Ball Bearing

GRIP TIGHT

D-LOK Ball Bearing

Series	Shaft Size	Weight lbs. kgs.	A	B	C	D	F Bolt Dia.	H	J	L	M	N
206	1	2.4	1.52	5.56	1.56	4.59	7/16	0.50	0.49	1.57	3.13	1.56
	25mm	1.0	38.6	141.2	39.6	116.7	M10	12.7	12.4	39.9	79.5	39.6
207	1-3/16	3.6	1.71	6.13	1.75	5.12	1/2	0.56	0.53	1.84	3.75	1.84
	1-1/4 30mm	3.5 1.6	43.4	155.7	44.5	130.0	M12	14.2	13.5	46.7	95.3	46.7
208	1-7/16	4.1	1.94	6.75	1.98	5.66	1/2	0.56	0.63	2.05	4.13	1.83
	35mm	1.9	49.3	171.5	50.3	143.8	M12	14.2	16.0	52.1	104.9	46.5
209	1-1/2	5.3	1.94	7.06	1.99	5.84	1/2	0.63	0.59	2.22	4.38	1.91
	1-5/8 40mm	5.2 2.3	49.3	179.3	50.5	148.3	M14	16.0	15.0	56.4	111.3	48.5
210	1-11/16	5.8	1.94	7.44	2.02	6.19	1/2	0.63	0.55	2.43	4.56	2.03
	1-3/4 45mm	5.6 2.6	49.3	189.0	51.3	157.2	M16	16.0	14.0	61.7	115.8	51.6
211	1-15/16	6.7	2.22	8.63	2.28	7.25	5/8	0.67	0.68	2.71	5.25	2.27
	2 50mm	6.5 2.9	56.4	219.2	57.9	184.2	M16	17.0	17.3	68.8	133.4	57.7
212	2-3/16	7.4	2.31	9.81	2.38	7.96	5/8	0.81	0.66	2.97	5.50	2.47
	2-1/4 55mm	7.2 3.2	58.7	249.2	60.5	202.1	M22	20.6	16.8	75.4	139.7	62.7

FEATURES/BENEFITS PAGE B4-3	HOW TO ORDER/NOMENCLATURE PAGE B4-5	SELECTION PAGE B4-6	ACCESSORIES PAGE B4-98
--------------------------------	--	------------------------	---------------------------