

SELECTION/DIMENSIONS

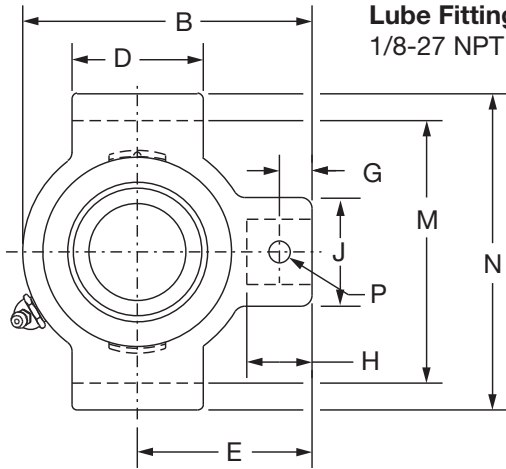

Setscrew Ball Bearings SC NORMAL DUTY NARROW SLOT TAKE-UP BEARINGS



Lube Fitting Thread Size:
1/8-27 NPT

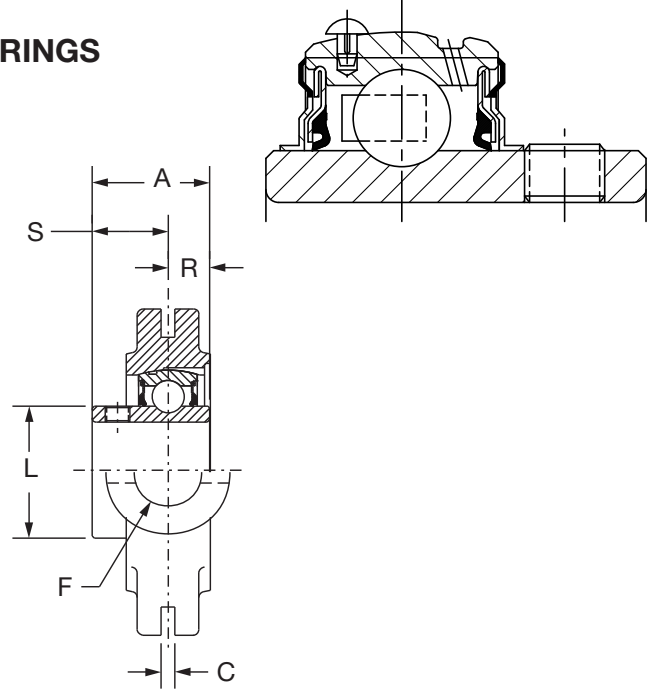

Series	Shaft Size	Standard		No Lube/Sealed for Life (-NL)	
		Part No.	Description	Part No.	Description
204	1/2	125328	NSTU-SC-008	@	NSTU-SC-008-NL
	5/8	125329	NSTU-SC-010	@	NSTU-SC-010-NL
	3/4	125050	NSTU-SC-012	073970	NSTU-SC-012-NL
	20mm	125900	NSTU-SC-20M	@	NSTU-SC-20M-NL
205	7/8	125365	NSTU-SC-014	@	NSTU-SC-014-NL
	15/16	125051	NSTU-SC-015	@	NSTU-SC-015-NL
	1	125052	NSTU-SC-100	125054	NSTU-SC-100-NL
	25mm	125901	NSTU-SC-25M	@	NSTU-SC-25M-NL
206	1-1/16	125366	NSTU-SC-101	@	NSTU-SC-101-NL
	1-1/8	125367	NSTU-SC-102	065642	NSTU-SC-102-NL
	1-3/16	125153	NSTU-SC-103	052194	NSTU-SC-103-NL
	1-1/4	123174	NSTU-SC-104S	@	NSTU-SC-104S-NL
207	30mm	125902	NSTU-SC-30M	@	NSTU-SC-30M-NL
	1-1/4	125154	NSTU-SC-104	058897	NSTU-SC-104-NL
	1-5/16	125368	NSTU-SC-105	065681	NSTU-SC-105-NL
	1-3/8	125369	NSTU-SC-106	125378	NSTU-SC-106-NL
	1-7/16	125155	NSTU-SC-107	052199	NSTU-SC-107-NL
35mm	125903	NSTU-SC-35M	@	NSTU-SC-35M-NL	

@ Assembled to order
See B15-9 for Take-Up Frames

FEATURES/BENEFITS PAGE B4-3	HOW TO ORDER/NOMENCLATURE PAGE B4-5	SELECTION PAGE B4-6	ACCESSORIES PAGE B4-98
--------------------------------	--	------------------------	---------------------------

SELECTION/DIMENSIONS



Setscrew Ball Bearings SC NORMAL DUTY NARROW SLOT TAKE-UP BEARINGS

Bearing Reference Guide

ULTRA KLEEN

E-Z KLEEN

Extreme Duty

Setscrew Ball Bearing

GRIP TIGHT

D-LOK Ball Bearing

Series	Shaft Size	Weight lbs. kgs.	Take-Up Frame No. Ref.	A	B	C	D	E	F Bolt Dia.	G	H	J	L	M	N	P Pin Dia.	R	S	
204	1/2	1.6	NS210	1.23	3.50	0.250	1.50	2.19	3/4	0.44	0.88	1.38	1.12	2.635/2.605	3.13	0.32	0.50	0.73	
	5/8	1.5		31.2	88.9	6.35	38.1	55.6	19.1	11.2	22.4	35.1	28.4	66.93/66.17	79.5	8.1	12.7	18.5	
	3/4	1.4																	
	20mm	0.8																	
205	7/8	1.7	NS210	1.34	3.56	0.250	1.50	2.19	3/4	0.44	0.88	1.38	1.32	2.635/2.605	3.13	0.32	0.56	0.78	
	15/16	1.6		34.0	90.4	6.35	38.1	55.6	19.1	11.2	22.4	35.1	33.5	66.93/66.17	79.5	8.1	14.2	19.8	
	1	1.5																	
	25mm	0.7																	
206	1-1/16	2.9	NS308	1.52	4.31	0.250	2.50	2.69	3/4	0.50	0.94	1.38	1.57	3.510/3.480	4.13	0.32	0.58	0.94	
	1-1/8	2.8																	
	1-3/16	2.7																	
	1-1/4	2.6																	
	30mm	1.2		38.6	109.5	6.35	63.5	68.3	19.1	12.7	23.9	35.1	39.9	89.15/88.39	104.9	8.1	14.7	23.9	
207	1-1/4	2.8	NS308	1.71	4.50	0.250	2.50	2.69	3/4	0.50	0.94	1.38	1.84	3.510/3.480	4.13	0.32	0.67	1.04	
	1-5/16	2.7																	
	1-3/8	2.6																	
	1-7/16	2.5																	
	35mm	1.2		43.4	114.3	6.35	63.5	68.3	19.1	12.7	23.9	35.1	46.7	89.15/88.39	104.9	8.1	17.0	26.4	

FEATURES/BENEFITS PAGE B4-3	HOW TO ORDER/NOMENCLATURE PAGE B4-5	SELECTION PAGE B4-6	ACCESSORIES PAGE B4-98
--------------------------------	--	------------------------	---------------------------

SELECTION/DIMENSIONS



Setscrew Ball Bearings SC NORMAL DUTY NARROW SLOT TAKE-UP BEARINGS

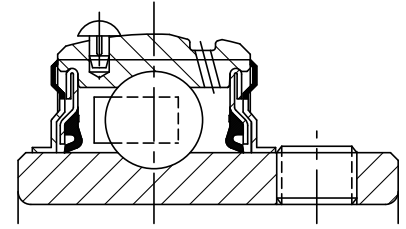
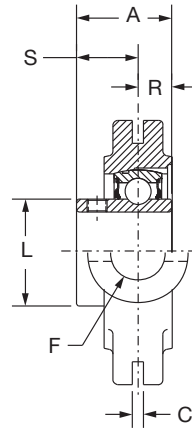
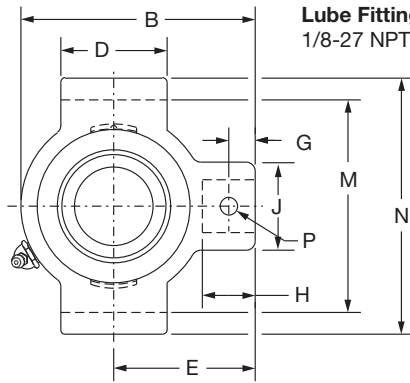

Series	Shaft Size	Standard		Sealed For Life	
		Part No.	Description	Part No.	Description
208	1-1/2	125156	NSTU-SC-108	@	NSTU-SC-108-NL
	1-5/8	125370	NSTU-SC-110	@	NSTU-SC-110-NL
	40mm	125904	NSTU-SC-40M	@	NSTU-SC-40M-NL
209	1-5/8	065593	NSTU-SC-110L	@	NSTU-SC-110L-NL
	1-11/16	125157	NSTU-SC-111	052939	NSTU-SC-111-NL
	1-3/4	125371	NSTU-SC-112	068184	NSTU-SC-112-NL
	45mm	125905	NSTU-SC-45M	@	NSTU-SC-45M-NL
210	1-15/16	125158	NSTU-SC-115	125159	NSTU-SC-115-NL
	2	125372	NSTU-SC-200	068659	NSTU-SC-200-NL
	50mm	125906	NSTU-SC-50M	@	NSTU-SC-50M-NL
211	2	135171	NSTU-SCM-200	@	NSTU-SCM-200-NL
	2-3/16	125160	NSTU-SC-203	@	NSTU-SC-203-NL
	2-1/4	125373	NSTU-SC-204	@	NSTU-SC-204-NL
	55mm	125907	NSTU-SC-55M	@	NSTU-SC-55M-NL
212	2-1/4	135172	NSTU-SCM-204	126544	NSTU-SCM-204-NL
	2-7/16	125162	NSTU-SC-207	073430	NSTU-SC-207-NL
	60mm	125908	NSTU-SC-60M	@	NSTU-SC-60M-NL

@ Assembled to order
See B15-9 for Take-Up Frames

Series	Shaft Size	Weight lbs. kgs.	Take-Up Frame No. Ref.	A	B	C *	D	E	F Screw Dia	G	H	J	L	M	N	P Pin Dia	R	S
208	1-1/2	4.7	NS400	1.94	5.38	0.313	3.00	3.25	7/8	0.66	1.16	1.63	2.05	4.015/3.985	4.75	0.38	0.75	1.19
	1-5/8	4.6		49.3	136.7	7.95	76.2	82.6	22.2	16.8	29.5	41.4	52.1	101.98/101.22	120.7	9.7	19.1	30.2
	40mm	2.1		49.3	136.7	7.95	76.2	82.6	22.2	16.8	29.5	41.4	52.1	101.98/101.22	120.7	9.7	19.1	30.2
209	1-5/8	4.9	NS400	1.94	5.44	0.313	3.00	3.25	7/8	0.72	1.22	1.63	2.22	4.015/3.985	4.75	0.38	0.75	1.19
	1-11/16	4.8		49.3	138.2	7.95	76.2	82.6	22.2	18.3	31.0	41.4	56.4	101.98/101.22	120.7	9.7	19.1	30.2
	1-3/4	4.7		49.3	138.2	7.95	76.2	82.6	22.2	18.3	31.0	41.4	56.4	101.98/101.22	120.7	9.7	19.1	30.2
	45mm	2.1		49.3	138.2	7.95	76.2	82.6	22.2	18.3	31.0	41.4	56.4	101.98/101.22	120.7	9.7	19.1	30.2
210	1-15/16	4.9	NS400	1.94	5.50	0.313	3.00	3.25	7/8	0.59	1.09	1.63	2.43	4.015/3.985	4.75	0.38	0.75	1.19
	2	4.8		49.3	139.7	7.95	76.2	82.6	22.2	15.0	27.7	41.4	61.7	101.98/101.22	120.7	9.7	19.1	30.2
	50mm	2.2		49.3	139.7	7.95	76.2	82.6	22.2	15.0	27.7	41.4	61.7	101.98/101.22	120.7	9.7	19.1	30.2
211	2	6.8	NS407	2.22	6.13	0.313	3.50	3.63	1	0.69	1.28	1.75	2.71	4.448/4.418	5.38	0.44	0.87	1.35
	2-3/16	6.6		56.4	155.7	7.95	88.9	92.2	25.4	17.5	32.5	44.5	68.8	112.98/112.22	136.7	11.2	22.1	34.3
	2-1/4	6.5		56.4	155.7	7.95	88.9	92.2	25.4	17.5	32.5	44.5	68.8	112.98/112.22	136.7	11.2	22.1	34.3
212	55mm	3.0	NS415	2.31	6.69	0.313	3.75	3.88	1	0.69	1.28	1.63	2.97	4.947/4.917	5.75	0.44	0.90	1.41
	2-1/4	8.7		58.7	169.9	7.95	95.3	98.6	25.4	17.5	32.5	41.4	75.4	125.65/124.89	146.1	11.2	22.9	35.8
	2-7/16	8.4		58.7	169.9	7.95	95.3	98.6	25.4	17.5	32.5	41.4	75.4	125.65/124.89	146.1	11.2	22.9	35.8
	60mm	4.9																

#+.010, -.020" +.25mm, -.50mm

FEATURES/BENEFITS PAGE B4-3	HOW TO ORDER/NOMENCLATURE PAGE B4-5	SELECTION PAGE B4-6	ACCESSORIES PAGE B4-98
--------------------------------	--	------------------------	---------------------------