

**Elastomers In Compression (Spiders)**

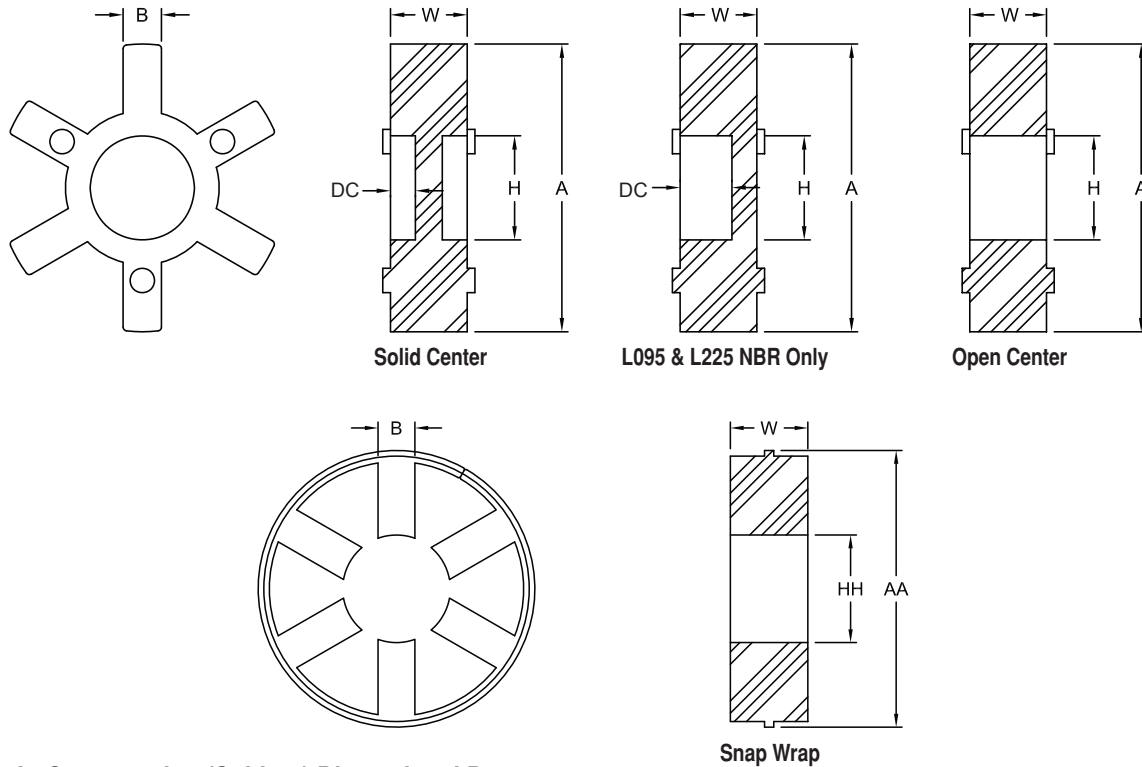

**Elastomers In Compression (Spiders) Dimensional Data**

Size	Material Available				A in	DC in	H in	Material Available				Material Available				Snap Wrap Spiders		All		
	NBR	Urethane	Hytrel®	Bronze				NBR	Urethane	Hytrel®	Bronze	NBR	Urethane	HYT	BRZ	NBR	in	HH	W	B
	SOX	URE	HYT	BRZ				SOX	URE	HYT	BRZ	in	in	in	in	in	in	in	in	in
L035	X	—	—	—	0.62	—	—	—	—	—	—	—	—	—	—	N/A	—	—	0.28	0.21
L050	X	X	X	—	1.07	—	—	—	—	—	X	1.07	0.31	0.31	N/A	—	—	0.42	0.27	
L070	X	X	—	—	1.38	—	—	X	X	X	X	1.38	0.50	0.50	N/A	—	—	0.42	0.27	
L075	X	—	—	—	1.75	—	—	X	X	X	X	1.75	0.75	0.75	N/A	—	—	0.44	0.27	
L090/L095	X	—	—	—	2.12	0.18	0.88	X	X	X	X	2.12	0.88	0.75	X	2.56	1.06	0.44	0.36	
L099/L100	X	—	—	—	2.54	0.25	1.03	X	X	X	X	2.54	1.03	1.03	X	3.08	1.37	0.61	0.43	
L110	X	—	X	—	3.31	NBR .25	1.19	X	X	X	X	3.31	1.18	1.38	X	3.87	1.50	0.75	0.45	
						HYT .18														
L150	X	—	X	—	3.75	NBR .31	1.25	X	X	X	X	3.75	1.25	1.125	X	4.56	1.75	0.88	0.59	
						HYT .21														
L190	X	—	X	—	4.50	NBR .31	1.38	X	X	X	X	4.50	1.38	1.38	X	5.18	2.25	0.88	0.60	
						HYT .18														
L225	X	—	X	—	4.98	NBR .38	1.75	X	X	X	X	4.98	1.75	1.75	URE	5.44	2.75	0.88	0.73	
						HYT .18														
L276	—	—	—	—	—	—	—	X	—	—	X	6.19	1.75	1.75	N/A	—	—	1.45	0.75	

Notes: ■ X indicates: Applicable.  
 ■ See pages JW-5 and JW-9 for more information on spiders.

# L Type Spiders / Hub Spline Bores Item Selection

JW

## L Type Coupling

- Sizes range from L035 to L276
- Ordering requires selecting UPC numbers for two standard L hubs and one standard open or solid center elastomer (spider)

## SW Type Coupling

- Sizes range from L090 to L190
- Ordering requires selecting UPC numbers for two standard L hubs and one snap wrap spider with snap ring
- Both L and SW Type couplings, select hubs from the standard bore and keyway chart (pages JW-11 and JW-12) maximum RPM for SW + Ring is 1,750 RPM
- LC coupling uses a snap wrap spider with a collar instead of a retaining ring

## Jaw In-Shear Coupling

- Ordering requires selecting item numbers for two standard hubs, one In-Shear elastomer and one In-Shear ring. See pages JIS-1 through JIS-4



## L Type Spider UPC Number Selection Table

Spider Type	Coupling Size										
	L035	L050	L070	L075	L090/095	L099/100	L110	L150	L190	L225	L276
SOX (NBR) (Solid)	10118	10194	10406	10621	11070	11494	11724	12001	12274	12409	—
SOX (NBR) (open center)	—	—	10393	10620	10968	11492	11711	37880	37881	12406	12612
Urethane (Solid)	—	37786	10395	—	—	—	—	—	—	12417	—
Urethane (open center)	—	—	10411	10626	11075	11499	11729	12006	12280	—	—
Hytrel® (Solid)	—	25307	—	—	—	—	11717	11993	12265	12401	—
Hytrel® (open center)	—	—	25308	25309	25310	11486	38097	38098	38099	12400	—
Bronze (open center)	—	10198	10409	10624	11073	11497	11727	12004	12277	34517	25767
Snap Wrap (NBR) w/ring	—	—	—	—	24669	24670	24671	24672	24673	—	—
Snap Wrap (NBR) w/o ring	—	—	—	—	11071	11495	11725	12002	12275	—	—
SOX (NBR) Bulk - pk 25	50115	50116	50117	50118	50119	—	—	—	—	—	—
SOX (NBR) Bulk - pk 10	—	—	—	—	—	51020	50121	50122	—	—	—
Snap Wrap Urethane - solid ring	—	—	—	—	—	41170	41171	—	28284	26093	—
In-Shear Elastomer	—	—	—	—	67576	67577	67578	67579	67580	68559	67581
In-Shear Ring	—	—	—	—	67584	67585	67586	67587	67588	68560	67589

Note: ■ When referencing the Lovejoy UPC number in this table, include 685144 as a prefix to the number shown.

## L Type Hub - Spline Bore UPC Number Selection Table

Teeth	Pitch	SAE	Spline Bore Diameters		Major Dia	Coupling Size								
			Major	Minor		L090	L095	L099	L100	L110	L150	L190	L225	L276
9	16/32	A	0.651	0.509	0.625	38568	37900	38571	37904	—	—	—	—	—
11	16/32		0.776	0.631	0.750	38569	37901	38572	37905	37909	37917	37925	—	—
13	16/32	B	0.901	0.754	0.875	38570	37902	38573	37906	37910	37918	37926	37935	—
13	8/16	D, E	1.798	1.506	1.750	—	—	—	—	37915	37923	37931	37940	38576
14	12/24	C	1.289	1.087	1.250	—	—	—	—	37912	37920	37928	37937	38577
15	16/32	BB	1.026	0.877	1.000	—	—	38574	37907	37911	37919	37927	37936	38578
21	16/32		1.401	1.250	1.375	—	—	—	—	37913	37921	37929	37938	—
23	16/32		1.526	1.375	1.500	—	—	—	—	37914	37922	37930	37939	—
27	16/32		1.776	1.625	1.750	—	—	—	—	37916	37924	37932	37941	38579
15	8/16	F	2.048	1.753	2.000	—	—	—	—	—	—	37933	37942	—

- Notes: ■ All pressure angles on above splines = 30°. Class 5 fit is standard, unless otherwise specified.  
 ■ All stock spline bore hubs are supplied standard with Lovejoy's exclusive L-LOC Clamping Feature. See page T-7 for description.  
 ■ When referencing the Lovejoy UPC number in this table, include 685144 as a prefix to the number shown.

**Performance Data**

**Spider Performance Data**

**Chart 2**

Characteristics	Temperature Range	Misalignment		Shore Hardness <sup>1</sup>	Dampening Capacity	Chemical Resistance <sup>2</sup>	Color
		Angular Degree	Parallel Inch				
SOX (NBR) Rubber – Nitrile Butadiene (Buna N) Rubber is a flexible elastomer material that is oil resistant, resembles natural rubber in resilience and elasticity and operates effectively in temperature range of -40° to 212° F (-40° to 100° C). Good resistance to oil. Standard elastomer. (Also applies to SXB Cushions.)	-40° to 212° F -40° to 100° C	1°	.015	80A	HIGH	GOOD	BLACK
URETHANE – Urethane has greater torque capability than NBR (1.5 times), provides less dampening effect, and operates at a temperature range of -30° to 160° F (-34° to 71° C). Good resistance to oil and chemicals. Not recommended for cyclic or start/stop applications.	-30° to 160° F -34° to 71° C	1°	.015	55D L050-L110 90-95A L150-L225	LOW	VERY GOOD	BLUE
HYTREL® – Hytrel is a flexible elastomer designed for high torque and high temperature operations. Hytrel can operate in temperatures of -60° to 250° F (-51° to 121° C) and has an excellent resistance to oil and chemicals. Not recommended for cyclic or start/stop applications.	-60° to 250° F -51° to 121° C	1/2°	.015	55D	LOW	EXCELLENT	TAN
BRONZE – Bronze is a rigid, porous oil-impregnated metal insert exclusively for slow speed (maximum 250 RPM) applications requiring high torque capabilities. Bronze operations are not affected by extreme temperatures, water, oil, or dirt.	-40° to 450° F -40° to 232° C	1/2°	.010	—	NONE	EXCELLENT	BRONZE

Notes: ■ 1 indicates: NBR standard shore hardness is 80A ±5A – Except L035=60A. Other softer or harder designs are available in NBR material; consult Lovejoy.  
 ■ 2 indicates: Chemical Resistance chart shown in Engineering Data Section (page ED-9).

**Jaw Nominal Rated Torque Data**

**Chart 3**

Size	Max Bore		Spider Material							
	in	mm	SOX (NBR) Torque		Urethane Torque		Hytrel Torque		Bronze Torque	
			in-lbs	Nm	in-lbs	Nm	in-lbs	Nm	in-lbs	Nm
L035	0.375	9	3.5	0.4	—	—	—	—	—	—
L/AL050	0.625	16	26.3	3.0	39	4.5	50	5.60	50	5.60
L/AL070	0.750	19	43.2	4.9	65	7.3	114	12.90	114	12.90
L/AL075	0.875	22	90.0	10.2	135	15.3	227	25.60	227	25.60
L/AL090	1.000	25	144.0	16.3	216	24.4	401	45.30	401	45.30
L/AL095	1.125	28	194.0	21.9	291	32.9	561	63.40	561	63.40
L/AL099	1.188	30	318.0	35.9	477	53.9	792	89.50	792	89.50
L/AL100	1.375	35	417.0	47.1	626	70.7	1,134	128.00	1,134	128.00
L/AL110	1.625	42	792.0	89.5	1,188	134.0	2,268	256.00	2,268	256.00
L150	1.875	48	1,240.0	140.0	1,860	210.0	3,708	419.00	3,706	419.00
AL150	1.875	48	1,450.0	163.8	—	—	—	—	—	—
L190	2.125	55	1,728.0	195.0	2,592	293.0	4,680	529.00	4,680	529.00
L225	2.625	65	2,340.0	264.0	3,510	397.0	6,228	704.00	6,228	704.00
L276	2.875	73	4,716.0	533.0	—	—	—	—	12,500	1 412.00
C226	2.500	64	2,988.0	338.0	—	—	5,940	671.00	5,940	671.00
C276	2.875	73	4,716.0	533.0	—	—	9,432	1 066.00	—	—
C280	3.000	76	7,560.0	854.0	—	—	13,866	1 567.00	—	—
C285	4.000	102	9,182.0	1 038.0	—	—	16,680	1 882.00	—	—
C295	3.500	89	11,340.0	1 281.0	—	—	22,680	2 563.00	22,680	2 563.00
C2955	4.000	102	18,900.0	2 136.0	—	—	37,800	4 271.00	37,800	4 271.00
H3067	4.500	114	33,395.0	3 774.0	—	—	47,196	5 333.00	47,196	5 333.00
H3567	5.000	127	46,632.0	5 269.0	—	—	63,000	7 119.00	63,000	7 119.00
H3667	5.629	143	64,812.0	7 323.0	—	—	88,200	9 966.00	88,200	9 966.00
H4067	6.250	159	88,224.0	9 969.0	—	—	126,000	14 237.00	126,000	14 237.00
H4567	7.000	178	119,700.0	13 525.0	—	—	170,000	19 209.00	170,000	19 209.00

Note: ■ Bronze has a maximum RPM capability of 250 RPM.

## Elastomers In Compression

Lovejoy offers four types of elastomer designs to allow for additional flexibility in addressing specific application requirements. One piece designs are used in the “L” and “AL” models (referred to as spiders) and multiple part “load cushions” are used in the “C” and “H” model couplings. The load cushions are in sets of 6 to 14 pieces depending on coupling size.

### Solid Center Spider

- The solid center design is commonly used design when shafts of the driver and driven equipment can be kept separate by a standard gap

### Open Center Spider

- The open center design allows for the shafts of the driver and driven to be positioned within a short distance
- Open center spiders offer shaft positioning flexibility but have a lower RPM capacity (1,750 RPM maximum for NBR, 3,600 maximum for Urethane/Hytrel®)

### Cushions

- Used exclusively for the C and H Type couplings
- Load cushions are held in place radially by a steel collar which is attached to one of the hubs

### Snap Wrap Flexible Spider

- Design allows for easy removal of the spider without moving the hubs
- Allows for close shaft separation all the way up to the hubs maximum bore
- Maximum RPM is 1,750 RPM with the retaining ring, but if used with the LC Type (with collar) the normal RPM rating of the coupling applies
- Style is available in NBR and Urethane only, and in limited sizes

Note: ■ Complete technical data for the new Jaw In-Shear elastomer is contained in the next section of this catalog, labeled “JIS” on the page tabs.



## Spider Materials

### SOX (NBR) Rubber

- The standard material that is highly flexible material that is oil resistant
- Resembles natural rubber in resilience and elasticity, and operates effectively in temperature ranges of -40° to 212° F (-40° to 100° C)

### Urethane

- Has 1.5 times greater torque capacity than NBR
- Good resistance to oil and chemicals
- Material provides less dampening effect and operates at a temperature range of -30° to 160° F

### Hytrel

- Flexible elastomer designed for high torque and high temperature operations
- Operates in temperatures of -60° to 250° F (-51° to 121° C)

### Bronze

- Rigid, porous, oil-impregnated metal insert exclusively for low speed (max 250 RPM) applications requiring high torque capabilities
- Not affected by water, oil, dirt, or extreme temperatures – operates in temperatures of -40° to 450° F (-40° to 232° C)



## WARNING

You must refer to page JW-2 (Page 14) for Important Safety Instructions and Precautions for the selection and use of these products. Failure to follow the instructions and precautions can result in severe injury or death.